

MAR 17 1969

**Dielectric properties of the hydrates of argon and nitrogen<sup>1</sup>**

S. R. GOUGH, E. WHALLEY, AND D. W. DAVIDSON

*Division of Applied Chemistry, National Research Council of Canada, Ottawa, Canada*

Received December 5, 1967

The dielectric relaxation of water in the structure I clathrate hydrates of argon and nitrogen was studied over a range of temperature and pressure. Hydrates were slowly grown at pressures of 1 to 2 kbar in a coaxial cell enclosed in a pressure vessel. The complex permittivity loci resemble circular arcs with static dielectric constants of  $\sim 56$  at  $0^\circ\text{C}$  and high-frequency dielectric constants of  $2.85 \pm 0.05$ . Relaxation near  $0^\circ\text{C}$  is about as slow as in ice I, but activation energies and entropies are much smaller. Formation of Bjerrum defects probably takes place preferentially near the occasional sites at which argon and nitrogen molecules have replaced water molecules in the lattice. The much faster relaxations found previously in the isostructural hydrates of ethers arise from orientational defects induced in the water lattice by the encaged molecules, a small proportion of which may form hydrogen bonds with water. The effect of small gaps in series with samples showing circular-arc dispersion behavior was evaluated.

Canadian Journal of Chemistry, 46, 1673 (1968)

Dielectric relaxation associated with the re-orientation of water molecules in ice (1, 2) and its high-pressure modifications (3, 4) has been previously studied. The gas, or clathrate, hydrates (5) are further examples of ices whose lattices consist of hydrogen-bonded four-coordinated water molecules. Stability is conferred upon these hydrates by the presence in the lattice cages of guest molecules, which typically seem to interact only weakly with the water molecules of the host lattice (5, 6).

The earlier dielectric studies of the water relaxation in clathrate hydrates were mainly confined to hydrates of rather large water-soluble ethers and ketones, viz. those of acetone (7); ethylene oxide (8); tetrahydrofuran, 2,5-dihydrofuran, propylene oxide, and trimethylene oxide (9); 1,3-dioxolane (10); dimethyl ether and cyclobutanone (11). In these hydrates the relaxation rates were found to be several orders of magnitude faster than in ice I and the activation energies only about half as great. Although the shapes of the dispersion loci appeared to be characteristic of the lattice structure for the structure II hydrates (9-11), the relaxation rates depended somewhat on the nature of the guest molecules. Except for the structure I hydrate of ethylene oxide (12), the smaller cages of all these hydrates are essentially unoccupied. Moreover, all of these hydrate formers are capable of relatively strong interaction, i.e. of hydrogen bonding, with water molecules. It is known from microwave absorption measurements (6)

that in ethylene oxide and tetrahydrofuran hydrates the rotation of the guest molecules is only slightly hindered, but this does not exclude the possibility that a guest molecule may occasionally hydrogen bond to a lattice water molecule. Since these factors may well affect the details of the mechanism of relaxation of the water lattice, it is of considerable interest to examine the relaxation behavior of hydrates of small nonpolar molecules which fill both large and small cages almost quantitatively and which are incapable of hydrogen bonding to the water molecules of the lattice.

The results of a study of the temperature and pressure dependence of the dielectric properties of argon and nitrogen hydrates are reported here. Argon is the smallest molecule known to form a clathrate hydrate. Its hydrate is stable at  $0^\circ\text{C}$  under argon pressures greater than 96 bars (13). Nitrogen hydrate is stable at  $0^\circ\text{C}$  under pressures above 160 bars (13, 14). The decomposition pressures of both hydrates reach 1700 bars at  $25^\circ\text{C}$ .

**Experimental Methods**

The cell (shown schematically in Fig. 1) consisted of a three-terminal stainless-steel coaxial electrode system mounted in a Teflon cylinder B which was contained by a brass sleeve. The bottom of B was attached to the lower pressure head by the binding post C, which was electrically connected to the outer (high-potential) electrode. The low-potential electrode A was guarded at the bottom. A brass ring D provided shielding between the binding posts C and E in the gas-filled region where their mutual capacitance would otherwise be variable. A small fixed capacitance resulted from interaction within the insulation between binding posts and mounting screws. This

<sup>1</sup>Issued as NRCC No. 9962.



and the cell constant were measured by calibration with air, cyclohexane, and conductivity water. The electrical connections, seals, and pressure vessel were as previously described (2).

Pressure was generated by a compressed-air-driven oil pump and transmitted to argon or nitrogen by a 3-kbar gas compressor. Pressures were read on a large calibrated 3-kbar Heise gauge. The pressure vessel containing the cell was immersed in an ethanol bath cooled to as low as  $-100^{\circ}\text{C}$  by a three-stage refrigeration unit designed and built by the Plant Engineering Division of NRCC. The bath temperature was regulated by adjustment of the flow rate of refrigerant through the cooling coils and by thermistor-controlled immersion heaters. Temperatures were measured by a calibrated copper-constantan thermocouple F (Fig. 1) inserted into the lower head of the pressure vessel to within 3'' of the center of the sample.

Capacitance and loss between 50 Hz and 500 kHz were measured by the earlier methods (15). For nitrogen hydrate measurements were extended to 0.05 Hz by use of a low-frequency bridge constructed according to a design of Professor R. H. Cole, to whom we are indebted.

The hydrates were grown in situ by subjecting freshly degassed conductivity water to gas pressures much above the hydrate decomposition pressure. Formation of hydrate, which was followed by changes in the dielectric properties of the sample, was very slow, presumably because of a hydrate crust formed at the water-gas interface. Repeated temperature and pressure cycling between about  $+10$  and  $-40^{\circ}\text{C}$  and 1 and 3 kbar increased the formation rate, probably by cracking this crust. Even so, complete conversion to hydrate usually required from 3 to 5 weeks.

The problem of quantitative formation of clathrate hydrates of water-insoluble molecules, even with shaking, has long plagued attempts to define their compositions accurately. (See, for example, ref. 16 for a review of early disagreements in analyses, and ref. 13 for a recent unsuccessful attempt to directly determine the composition of methane hydrate.) For the present hydrates, the conductances measured at frequencies small in comparison with the frequency of maximum dielectric absorption were particularly sensitive to small quantities of water in the sample and served to monitor the disappearance of liquid water. Excess water in a sample of argon hydrate formed at 3 kbar led at low temperatures to a separate absorption region at higher frequencies whose amplitude diminished with conditioning and which was attributed to ice III.

## Results

### *The Dispersion Loci*

Typical experimental complex dielectric constant plots of argon and nitrogen hydrates are given in Figs. 2 and 3. In some 50 such curves were obtained. The shapes conform quite closely to depressed circular arcs. The Cole-Cole  $\alpha$  parameter increases greatly with decreasing temperature from values of about 0.1 at temperatures above  $0^{\circ}\text{C}$  to 0.25 (for nitrogen hydrate) at  $-70^{\circ}\text{C}$ . The dispersion loci of

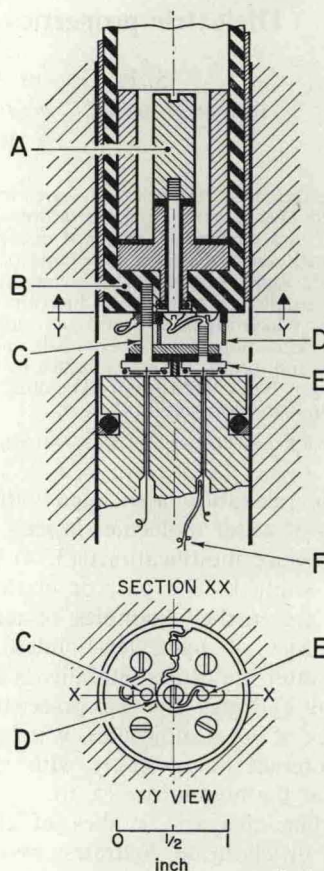

FIG. 1. Schematic of dielectric cell assembly.

nitrogen hydrate are somewhat broader than those of argon hydrate at the same temperature.

As with the hydrates previously studied (7, 9, 10) there are noticeable departures from arcs at low temperatures, especially at high frequencies where  $\epsilon''$  approaches the  $\epsilon'$  axis more steeply than the circular arc. Departures of this kind also are observed on the low-frequency side of the absorption region when not obscured by the additional absorption associated with ionic conductance (see Fig. 3, upper locus).

In deriving dielectric parameters from the experimental data, we have taken the Cole-Cole representation (see eq. [1], p. 1676) to be adequate, except for  $\epsilon_{\infty}$ , which was obtained by extrapolation to the  $\epsilon'$  axis of the high-frequency side of the experimental locus rather than from the best fit of a circular arc to the locus as a whole.